



E-Track Mount Survey

TO INSTALL A GATEWAY ROLL-UP DOOR UNDER OR IN FRONT OF A ROLLING / COILING STEEL DOOR

1) APPLICATION

UNDER HOOD

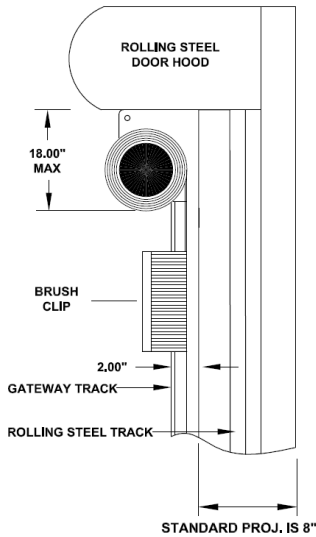

IN FRONT OF HOOD

NOTE: If existing door has front-mounted motor, your Gateway door must mount *under* the hood.

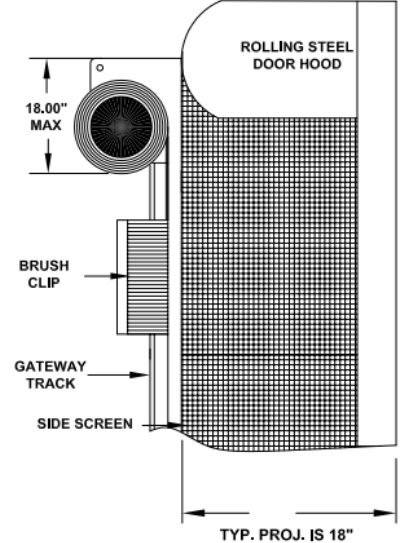

2) DOOR OPENING MEASUREMENT:

Wide x High

3) OUT-TO-OUT TRACK DIMENSIONS

A. At the bottom of the track

B. At the top of the track

4) TRACK PROJECTION FROM WALL

C. At the bottom of the track

D. At the top of the track

E. Hood Projection

5) HEIGHT

F. Floor to bottom of Hood

G. Floor to top of Hood

6) IF BOLLARDS

H. Out-to-Out of Bollards

I. Bollard diameter

J. From wall to front of bollard

